

ATTACHMENT B
Robert Street Improvements
Grade-Separated Trail Crossing Feasibility Study



ROBERT STREET IMPROVEMENTS

GRADE SEPARATED TRAIL CROSSING FEASIBILITY STUDY

FINAL REPORT - JUNE 2011

City of West St. Paul





June 6, 2011

SRF No. 0107294

Honorable Mayor and City Council
CITY OF WEST SAINT PAUL
1616 Humboldt Avenue
West Saint Paul, MN 55118

SUBJECT: ROBERT STREET IMPROVEMENTS – GRADE SEPARATED TRAIL CROSSING
FEASIBILITY STUDY
CITY PROJECT NO. 11-3

Dear Mayor and Members of the Council:

Enclosed please find the Feasibility Study Report for the grade separated trail crossings for the Robert Street Improvements. On November 8, 2010 the City Council authorized SRF Consulting Group, Inc. to proceed on the project as part of our consultant agreement contract approval.

The project, proposed herein, is consistent with the City's Comprehensive Plans and is necessary, cost-effective and feasible from an engineering perspective to provide a grade separated trail crossing.

We would be pleased to meet with the City Council, staff, and other interested parties to review any aspect of this report.

Sincerely,

SRF CONSULTING GROUP, INC.

Kevin L. Swehla, PE (MN KS MO ND WI)
Senior Associate

David E. Hutton, PE (MN WI)
Senior Associate

KLS/DEH/gjb

Enclosure

H:\Projects\7294\BR\Doc\Feasibility Study\Feasibility Study 2011.docx

www.srfconsulting.com

One Carlson Parkway North, Suite 150 | Minneapolis, MN 55447-4443 | 763.475.0010 Fax: 763.475.2429

An Equal Opportunity Employer

FEASIBILITY REPORT FOR

City Project No. 11-3

Robert Street Improvements – Grade Separated Trail Crossing

West Saint Paul, Minnesota

June 2011

I hereby certify that this plan, specification, or report was prepared by me or under my direct supervision and that I am a duly Licensed Professional Engineer under the laws of the State of Minnesota.

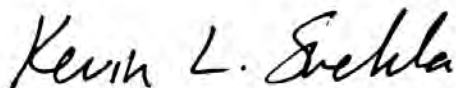

Kevin L. Swehla, P.E.

Date: June 6, 2011

Reg. No. 42791

Table of Contents

Executive Summary.....	1
Introduction.....	3
Study Objectives.....	3
Crossing Location/Trail Connections.....	4
Bridge/Tunnel Approach Options.....	6
Structure Type.....	9
Bridge Aesthetics.....	10
Site Options for West Approach – Parks, Open Space and Transit.....	11
Easement/Right of Way (ROW) Acquisitions.....	12
Project Costs.....	12
Summary and Recommendations.....	13
Appendix.....	14
A Site Photos Near Crawford Drive	
B North Urban Regional Trail (NURT) Options	
C Approach & Bridge/Tunnel Profile	
D Bridge/Tunnel Crossing At Crawford Drive Options	
E Structure Type Cross Sections & Examples	
F Pedestrian Bridge Concepts	
G Bridge/Tunnel Crossing Cost Estimate Matrix	

Executive Summary

Robert Street serves as the main north-south corridor through the heart of the commercial business district in West Saint Paul. It is generally characterized by small and large business developments, high traffic volumes, extensive existing public transportation, and planned future expansion of public transportation options. This report assesses the feasibility of constructing a grade separated trail at Robert Street. The intent of this grade separated trail crossing is to connect local trails, a planned regional trail, public and recreational facilities, local businesses, public transportation, surrounding residential neighborhoods, and provide an alternative to the at-grade crossing at Wentworth Avenue that exists today.

The vicinity of Wentworth Avenue and Robert Street was identified as an ideal area for the grade separated trail crossing due to the proximity of the existing local trail, and the planned North Urban Regional Trail (NURT) along Wentworth Avenue. According to Met Council estimates, the NURT has a projected ridership of 33,900. Crawford Drive is just to the north of Wentworth Avenue, and is the recommended location for the grade separated trail crossing. The area around Crawford Drive allows flexibility to accommodate future transit and green space, minimize business impacts, and allows for the use of existing Right of Way (ROW) on the east side of Robert Street. Appendix B of this report identifies potential trail connection segments to connect the local trail and planned NURT with a crossing at Crawford Drive.

Sites around Crawford Drive can accommodate a variety of crossing approach configurations. Appendix D includes seven potential configurations (5 bridge options, and 2 tunnel options) that allow for a grade separated trail crossing within the assumed project limits. Also identified in these options is the amount of ROW acquisition necessary and area available for green space or mass transit accommodations.

The trail crossing can be constructed using a variety of structure types. An example of each structure type and a representative project is presented in Appendix E. While this report looked at both bridge and tunnel options, it is recommended that a bridge be considered as the preferred option. Tunnels are generally used in areas that are more open and less dense. In dense and fully developed urban areas, tunnels tend to be less aesthetically pleasing. They also can become havens for nuisance activities. While the tunnel costs may be less than a bridge, there could be substantial utility relocation costs added on to the project with the possibility of large numbers of public and private utilities below the street.

An elevated trail crossing (bridge) can establish a new tone for its surroundings and has the potential to become an important community landmark for years to come. Two aesthetic concepts in Appendix F are being presented for initial consideration. These concepts will need substantial further design development and will evolve as the project progresses.

A preliminary estimate of project costs for the trail crossing range from \$2.1 to \$3.5 million in 2011 dollars. This estimated cost does not include Right of Way (ROW) acquisition.

There are numerous combinations of bridge approach types, structure types and impacts on nearby properties presented in this study. Most of the combinations presented can be used for both the bridge and tunnel options. Each are viable, and provide various opportunities for transit use, public gathering spaces, and connectivity to the Robert Street Corridor and other facilities. Therefore, it is difficult to recommend one concept over another. The preferred concept should be chosen based on an evaluation of community priorities.

City of West Saint Paul Robert Street Improvements – Grade Separated Trail Crossing

Feasibility Study June 2011

Introduction

Robert Street serves as the main north-south corridor through the heart of the commercial business district in West Saint Paul, and is part of the trunk highway system (T.H. 952). This corridor is generally characterized by small and large commercial business developments, high traffic volumes, extensive existing public transportation, and planned future expansion of public transportation options.

In early 2010, the City of West St. Paul was awarded Surface Transportation Program (STP) funding for improvements to the Robert Street corridor for use in federal fiscal year 2014. Planned improvements to Robert Street include: mill and overlay of bituminous pavement, utility upgrades, construction of a raised center median, safety improvements to intersections, consolidation of access points to improve safety, landscaping, and a grade separated trail crossing in the center of the corridor. The grade separated trail crossing is the focus of this feasibility study.

The intent of this grade separated trail crossing over Robert Street is to provide safe access to:

- Local trails, and the planned Dakota County North Urban Regional Trail (NURT)
- Public facilities (West St. Paul Municipal Center and Dakota County Wentworth Library)
- Recreational facilities (Marthaler Park, South Family YMCA, Thompson Oaks Golf Course, West Saint Paul Sports Complex)
- Local commercial businesses
- Public transportation
- Adjacent residential neighborhoods

This study was made possible through funding from the Statewide Health Improvement Program (SHIP) of the Minnesota Department of Health. For more information on this program, visit www.health.state.mn.us/healthreform/ship.

Study Objectives

A grade separated trail crossing over Robert Street would provide pedestrians and bicyclists an alternative to the at-grade crossings that exist today. The purpose of this study is to:

- Identify potential locations for a new grade separated trail crossing of Robert Street
- Identify potential routes that would connect the grade separated crossing back into the planned Dakota County North Urban Regional Trail (NURT)
- Conduct conceptual analysis of the recommended trail crossing site and develop multiple trail alignments for consideration

- Identify areas near the crossing that could be used for future transit accommodations or green space.
- Identify impacts to properties adjacent to the trail crossing and potential right of way acquisitions
- Outline potential structure types and aesthetic options
- Provide cost estimate of the proposed improvements
- Provide recommendations for viable alternatives

Crossing Location/Trail Connections

An existing trail along Wentworth Avenue serves the community as a connection between nearby public facilities, local parks and recreation areas, commercial retail properties, and nearby neighborhood developments. The existing trail has also been identified as part of the larger Dakota County North Urban Regional Trail (NURT) plan. Given these existing parameters, a grade separated trail crossing of the Robert Street corridor in the vicinity of the Wentworth Avenue and Robert Street intersection is the most desirable location.

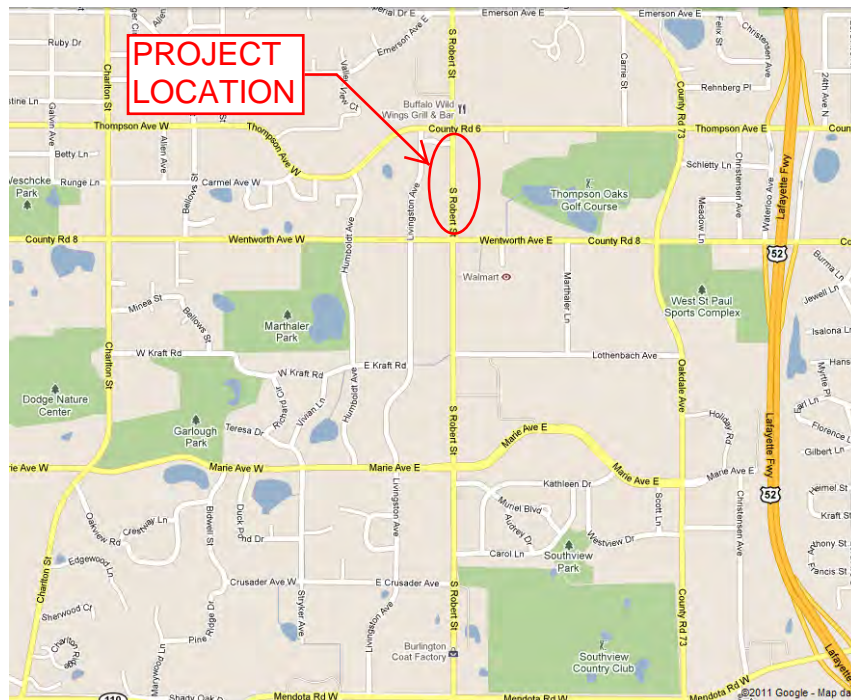

The anticipated primary users of the crossing include local pedestrian traffic along the Robert Street corridor, as well as recreational trail users anticipated to utilize the crossing as a means to bypass at-grade Robert Street crossings. In April 2011, the Metropolitan Council released a report entitled the “Annual Use Estimate of the Metropolitan Regional Parks System for 2010” which reviewed visitation data from 2007 through 2010. This report indicates a projected 33,900 annual trail users will access the planned NURT.

Investigation of potential grade separated trail crossing site locations included a review of existing land uses and field observation of the corridor with City staff. A grade separated trail

crossing located at the Wentworth Avenue and Robert Street intersection itself is not feasible since it could create a safety hazard by blocking the sight lines for drivers at this signalized intersection. Existing retail south of Wentworth Avenue and the recent redevelopment in the northeast quadrant of Wentworth Avenue and Robert Street make sites north of Wentworth Avenue more practical options for the new crossing.

Crawford Drive, which is mid-way between Wentworth and Thompson Avenues, is the recommended location for the grade separated trail crossing. This location allows flexibility to accommodate future transit and green space, minimizes impacts to existing businesses, and allows for the use of existing right of way on the east side of Robert Street. Photos of the recommended site at Crawford Drive are located in Appendix A.

An alternate crossing location considered as a part of this study is approximately 250 feet north of Wentworth Avenue and Robert Street. While this location would be closer than Crawford Drive to the existing trail on Wentworth Avenue, accommodating a bridge or tunnel would require large amounts of right of way and have more significant business impacts than the Crawford Drive location. For this reason, this location was dismissed with no further study.

With the establishment of an appropriate grade separated crossing location of Robert Street, the existing and proposed routes for the NURT and its connection to the grade separated crossing were considered. Appendix B contains a comparison matrix and graphic for possible routes of the NURT through the Robert Street corridor between points A and B on the drawing. Those routes are described as follows:

The NURT West Connection – Option 1 is a route that provides a connection from the grade separated crossing to the existing trail on Wentworth Avenue via a new trail along Livingston Avenue.

The NURT West Connection – Option 2 would provide a similar connection through existing properties between Livingston Avenue and Robert Street. Option 2 would require the acquisition of additional trail easement/right of way.

The NURT East Connection – Option 1 continues the trail along the north edge of Thompson Oaks Golf Course to Thompson Avenue. This option does not make use of existing local trails along Wentworth Avenue east of Robert Street. In addition, it does not offer an easy connection to key public facilities, such as the Dakota County Wentworth Library and the West Saint Paul Sports Complex. However, it does provide better access to the YMCA and a more direct connection to parks and trails east/north of the crossing.

NURT East Connection – Option 2 takes the trail along the south edge of Thompson Oaks Golf Course to reconnect with the existing trail along Wentworth Avenue. This option uses more of the existing local trail, and provides better access to the Dakota County Wentworth Library and the West Saint Paul Sports Complex.

Bridge/Tunnel Approach Options

One of the key criteria for the project is to comply with the current Americans with Disabilities Act (ADA), International Building Code (IBC), and Minnesota Department of Transportation (MNDOT) Bikeway Facilities Manual design requirements. Current IBC code allows for designed grades to be set at a maximum 5% slope without requiring the use of landings based on ADA criteria. The IBC also allows grades up to 8.33% with the use of landings after every 2.5 feet of vertical rise. The use of a maximum 5% slope without landings is preferred to provide a smooth ride for trail users, and was the basis for this study. The MNDOT LRFD Bridge Design Manual requires that the vertical clearance between the lowest structural member of the bridge and Robert Street be a minimum of 17 feet 4 inches. This clearance height was used to determine the bridge elevation from which the length of bridge and approach could be estimated.

For similar reasons, the tunnel option was also designed with a 5% slope at the approaches. This was done to provide a smooth ride for trail users, and still achieve adequate cover between the surface of Robert Street and the top of the tunnel. A minimum vertical clearance in the tunnel of 10 feet was designed to comply with requirements of the MNDOT Bikeway Facilities Manual. Appendix C contains a schematic of the assumed bridge and tunnel profiles used to develop the crossing options.

Alignments were investigated to best serve the users and fit within site constraints. The MNDOT Bikeway Facility Design Manual requires a minimum 90-foot radius of curvature be used to accommodate the desired 20 mph design speed for bicyclists. Site constraints at the approaches will necessitate a design exception from State Aid Standards for most options considered, as a 90-foot radius cannot be achieved in all but one case.

Appendix D contains graphics for seven grade separated crossing concepts at Crawford Drive, along with a comparison matrix. In general, options indicating a bridge crossing could be constructed as a tunnel with moderate adjustments to the approach configurations. In addition, the approaches shown on either side of Robert Street are independent of one another, and generally could be used with another approach option. For instance, the helix shown on the east approach in Option A could be used with the oval alignment on the west approach in Option B. The exceptions to this are Options C, and tunnel options F and G, which cannot easily be mixed with different approach options.

The sites to the west of Robert Street (existing Blockbuster Video store and large parking lot) accommodate a wider variety of approach options, as there is more space available than on the east side of Robert Street at Crawford Drive.

The options for the west approach for a bridge crossing and some of their considerations are as follows:

1. Helix (Approach Option WA - Concept A)
 - a. Accommodates trail connection
 - b. Provides pedestrian access to Robert Street and future transit use area
 - c. Requires a design exception for trail design (curve radius less than 90 ft.)

- d. Requires acquisition of Blockbuster Video lots
2. Switchbacks (Approach Options WB, WC & WD - Concepts B, C & D)
 - a. Radius of curvature can be set to meet site land use requirements
 - b. Accommodates trail connection
 - c. Provides pedestrian access to Robert Street and future transit use area
 - d. Requires a design exception for trail design (curve radius less than 90 ft.)
 - e. Requires a retaining wall on the north side of the bridge approach along Napa Auto Parts store for Concept C and a retaining wall along the south side of the bridge approach for Concept D
 - f. Requires acquisition of Blockbuster Video lots
 3. Direct Trail Option to Livingston Avenue (Approach Option WE - Concept E)
 - a. Meets desired minimum trail radius of 90 feet for bicyclists
 - b. Provides most direct route for trail use
 - c. Does not provide access to pedestrian traffic from Robert Street
 - d. Does not provide direct access to land use for future transit
 - e. Requires a retaining wall along the west side of the bridge approach
 - f. Requires acquisition of Blockbuster Video lots

The bridge approach on the east side of Robert Street along the Crawford Drive corridor is constrained by the existing right of way (ROW), existing commercial buildings, and the location of Crawford Drive. A center median is anticipated as part of the Robert Street Improvement Project, which would restrict traffic movements at the Robert Street and Crawford Drive intersection to right turns only if Crawford Drive were to remain open at Robert Street. For this reason, various options were considered that would close Crawford Drive at Robert Street to accommodate the trail crossing. All options that close Crawford Drive at Robert Street require the entrance to Discount Tire to be relocated to Robert Street. In addition, access to driveways for future townhomes would need to be accommodated with an east-west leg of Crawford Drive that ends at the bridge approach.

The options for the east approach for a bridge crossing and some of their considerations are as follows:

1. Helix (Approach Option EA - Concept A)
 - a. Provides space for possible future transit use
 - b. Accommodates trail connection
 - c. Provides access to Robert Street and future transit use area
 - d. Requires a design exception for trail design (curve radius less than 90 ft.)
 - e. Requires closure of Crawford Drive
 - f. Requires relocation of existing AutoZone parking lot to an unused lot on the north side
2. Switchback (Approach Option EB - Concept B)
 - a. Larger radius of curvature than Concept A
 - b. Accommodates trail connection

- c. Provides access to Robert Street
 - d. Requires a design exception for trail design (curve radius less than 90 ft.)
 - e. Requires closure of Crawford Drive
 - f. Requires relocation of existing AutoZone parking lot to an unused lot on the north side
3. Switchback (Approach Option EC - Concept C)
 - a. Accommodates trail connection
 - b. Provides pedestrian access to Robert Street
 - c. No closure of Crawford Drive
 - d. Requires relocation of existing AutoZone parking lot to an unused lot on the north side
 - e. Very tight radius affecting the flow of bicycle traffic
 4. Switchback (Approach Option ED - Concept D)
 - a. Fits almost entirely within the limits of closed Crawford Drive right-of-way
 - b. Accommodates trail connection
 - c. Provides access to Robert Street
 - d. No impacts to AutoZone parking lot
 - e. Very tight radius affecting the flow of bicycle traffic
 5. Direct Trail Option along Crawford Drive (Approach Option EE - Concept E)
 - a. Minimum trail radius of 46.0'
 - b. Provides most direct route for trail use
 - c. No impacts to AutoZone parking lot
 - d. Closure of Crawford Drive outlet to Robert Street
 - e. Does not provide access to pedestrian traffic from Robert Street
 - f. Requires additional approach length as existing ground to the east of Robert Street is substantially lower

Options F and G depict tunnel options for the crossing. While a tunnel can be accommodated on the site, there are disadvantages to a tunnel over a bridge. Among the disadvantages of a tunnel are:

- Traffic on Robert Street would need to be reduced to one lane in each direction to allow for the construction of the tunnel, causing disruption to motorists and the business community.
- From a user viewpoint, tunnels in dense urban areas are generally not viewed as aesthetically pleasing. They are typically utilized where there is open space and surrounding green areas. Additionally, a bridge allows for a more visible community landmark and opportunities for pronounced gateway features.
- In order to provide pedestrian connections to Robert Street, “switchback approaches” will be needed. While the grade at Crawford Drive falls away from Robert Street on the east approach and would reduce the length of approach necessary to reach existing grade, the desire to connect back to Robert Street reduces or eliminates this advantage.
- A tunnel creates areas that are secluded and not visible to the public, especially in a dense urban environment.

While measures such as lighting and expansive approaches can help to mitigate these items, a tunnel is not recommended in this area.

A preliminary investigation into existing utilities has been done. Further utility investigation will continue in the preliminary design phase of the project. No major utilities have been identified that would preclude any of the bridge options from consideration. If a tunnel were to be chosen, existing utilities in the Robert Street corridor may need to be adjusted to clear the top of the tunnel and/or the tunnel set low enough to accommodate utility cover requirements. In addition, soil borings were not obtained as part of this report as these are generally done as part of the design phase.

A separate alternatives analysis to study transit in the Robert Street corridor is planned to be underway soon. While the study is not expected to be completed for 18 to 24 months, accommodating possible transit stops near the trail crossing was considered in this study. Space for possible transit needs along Robert Street at the trail crossing site has been denoted with the various options. All trail crossing concepts include some space for transit accommodations at the west approach site. Concept A allows space for transit accommodations at the east approach. In both cases, specific mass transit land uses remain undefined.

Structure Type

There are multiple structure types that could accommodate a grade separated trail crossing. Ease of construction, site constraints, and desired aesthetics are among the key elements when considering an appropriate structure type.

It is our opinion that the five structure types listed below are feasible for the Robert Street crossing:

- Prestressed Concrete Girder Bridge
- Prestressed Concrete Through Girder Bridge
- Steel Girder Bridge
- Prefabricated Steel Truss Bridge
- Precast Concrete Box Culvert Tunnel

The structure types listed for the bridges would apply to the main span over Robert Street, which is the visual focal point of the structure. Depending on which main span option was chosen, the approach spans may need to be another structure type. An approach span structure type such as formed concrete with shorter spans may better accommodate the tight curvature shown in several of the alignment options.

Appendix E contains a typical cross section of each structure type, along with examples of bridges (or tunnels) where these structure types were used.

The prestressed concrete girder with a concrete deck found on page 5 of 6 in Appendix E would require a greater structure depth than the other bridge alternatives. To maintain adequate

vertical clearance over the roadway, the increased depth associated with these alternatives creates a need for longer bridge approaches to achieve the higher deck elevations. This alternative is not recommended due to the tight site constraints, particularly at the east approach.

The prestressed concrete through girder, steel girder and prefabricated steel truss would all provide a shallower structure depth to accommodate the site constraints. While all viable alternatives are relatively similar in cost, they each provide a much different look. Further discussion on the aesthetic aspects of the structure type is in the following section.

The precast box culvert tunnel alternative can be found in Figure 6 of 6 in Appendix E. As stated in the previous section, this option is not recommended due to traffic impacts during construction, possible utility adjustments beneath Robert Street and safety concerns. A long enclosed tunnel would need additional lighting requirements for safety, and have limited visibility from Robert Street.

Bridge Aesthetics

Design informants - Crossing over Robert Street approximately midway between Thompson Avenue and Wentworth Avenue, the proposed pedestrian bridge will be a prominent civic design feature that will establish the precedent for the character of other potential streetscape enhancements incorporated into the Robert Street Reconstruction project. Reviewing the City of West St. Paul's Robert Street Renaissance Redevelopment Design Framework (2000), this segment of Robert Street was envisioned as a potential new "Town Center" created by guided redevelopment. The Framework established goals for the corridor including improved image and connectivity, continuity, and livability - with specific mention of balancing "the functional needs of traffic with a comfortable pedestrian environment." The initial sketch options for the aesthetic character of the bridge strive to create a landmark that fits sensitively within its urban surroundings and provides a recognizable destination for trail users on the proposed North Urban Regional Trail. Two concepts are being presented as part of this report for initial consideration.

- **Concept A** - The primary structure in Concept A found on Figure 1 of Appendix F is a prefabricated "bow-string" truss spanning the full roadway and sidewalk area with a visually prominent central arch. The approach spans are created with formed concrete. The vertical pier supports incorporate an arched portal that reduces the structure's perceived mass, opens visibility, and allows pedestrians and bicyclists to pass through it. The incorporation of brick and architectural precast concrete detailing into the concrete structure is inspired by aspects of exemplary traditional commercial streetfront architecture. Complementing the primary structural elements, decorative railings and lighting would be carried into the approach ramp and retaining wall structures.
- **Concept B** - The primary visual elements in Concept B found on Figure 2 of Appendix F are the vertical piers topped by decorative light towers and are inspired by a "prairie

style” character. The concrete piers could incorporate a natural stone veneer or a “formliner” surface treatment that suggests the appearance of natural stone. The light towers could incorporate a decorative art motif that would animate the street character both day and night. Both the main span and approach spans are created with girder beams. As in Concept A, decorative railings and potential lighting would be integrated with the overall design.

Aesthetics Summary - The concept sketches present two unique approaches intended to initiate and inform discussion and consideration of the desired structural type and other aesthetic aspects of the bridge and immediate surroundings. These concepts will need substantial further design development and will evolve as the project progresses. By sheer nature of its size and architectural character, the bridge will establish a new tone for its surroundings and has the potential to become an important community landmark for years to come.

Site Options for West Approach – Parks, Open Space and Transit

The City’s Park Master Plan (2000) indicates a desire to create a continuous greenway or open space trail system that builds on and utilizes existing parks, open spaces, and public lands. Marthaler Park and City Hall are located one block west and south of the proposed bridge location. A desire also exists to create a space that may accommodate future public transit uses at the site of the pedestrian crossing.

The site for the west approach will incorporate regional trail access, local pedestrian sidewalk traffic, and mass transit options into a space that can be used for multiple purposes. The planned North Urban Regional Trail will connect this area to regional park amenities and the Mississippi River. Green spaces can be created around the bridge structure to soften the feel of the surrounding commercial developments, as well as establish an attractive experience for users. Storm water treatment areas if needed could be included as site features that may contour the site and add a focal point.

The connection point between the trail, local pedestrian traffic, and mass transit could also be used as a regional trail orientation point. Items such as architectural kiosks, or a small trail rest area may be added to the site indicating points of interest along the regional trail accessible by way of the pedestrian crossing.

Small rest areas on the site or public gathering spaces around the mass transit use may also incorporate public art features to assist this location in becoming a new point of interest. Specific design of this area was not part of the scope for this report.

Easement/Right of Way (ROW) Acquisitions

Few open sites, or public land exist that would accommodate a grade separated trail crossing of Robert Street. Additional right of way (ROW) will need to be acquired on both the east and west of Robert Street to establish enough space for the approach to a grade separation structure.

The west approach options near Crawford Drive indicated in Options A thru G of Appendix D can all be established within the same ROW to be acquired. This includes the acquisition of 2 parcels of land which are both currently occupied by Blockbuster Video. These parcels are boarded to the east and west by public ROW, and together will act as continuous trail access from Livingston Avenue to Robert Street.

The recommended ROW acquisition on the west side of Robert Street near Crawford Drive is large enough to include areas for the west crossing approach, open green space, and future transit uses. Additional ROW will need to be acquired to establish the NURT trail connection outside the limits of this study.

The east approach options at Crawford Drive indicated in Options A thru G of Appendix D indicate multiple ROW acquisition requirements. ROW impacts of each Concept are as follows:

1. Options A, B, C & G:
 - a. Portion of YMCA facility north of Crawford Drive
 - b. Approximately half of the existing AutoZone parking lot north of Crawford Drive
 - c. An undeveloped parcel north of AutoZone to relocate acquired parking lot
2. Options D & E:
 - a. Small portion of planned townhome development south of Crawford Drive
 - b. Small portion of AutoZone north of Crawford Drive
 - c. Small portion of YMCA facility north of Crawford Drive
3. Option F:
 - a. Small portion of YMCA facility north of Crawford Drive
 - b. Approximately half of the existing AutoZone parking lot north of Crawford Drive
 - c. An undeveloped parcel north of AutoZone to relocate acquired parking lot

Project Costs

The grade separated trail crossing is anticipated to be built in 2014. A preliminary estimate of project costs was developed based on the grade separated trail crossing options presented in this study. A more detailed cost estimate should be performed as the design elements within the project become more defined.

The estimated cost for each option shown in Appendix D is as follows:

Crossing Option	Cost in 2011 Dollars	Cost in 2014 Dollars
Option A (Bridge)	\$2.7 million to \$2.9 million	\$3.0 million to \$3.2 million
Option B (Bridge)	\$3.0 million to \$3.3 million	\$3.3 million to \$3.6 million
Option C (Bridge)	\$3.2 million to \$3.5 million	\$3.5 million to \$3.8 million
Option D (Bridge)	\$2.8 million to \$3.1 million	\$3.1 million to \$3.4 million
Option E (Bridge)	\$2.9 million to \$3.2 million	\$3.2 million to \$3.5 million
Option F (Tunnel)	\$2.5 million to \$3.0 million	\$2.7 million to \$3.3 million
Option G (Tunnel)	\$2.1 million to \$2.6 million	\$2.3 million to \$2.8 million

These costs include a 10% contingency and an estimated 20% for engineering and construction administration cost. **These costs do not reflect any right of way acquisition that would be necessary.** A breakdown of the various components considered when developing these cost estimates can be found in Appendix G.

The estimated costs apply to any of the structure types suggested previously, as there is generally not a great deal of variability in structure type cost for pedestrian bridges as there is for vehicular bridges. This is due to the higher substructure to superstructure ratio that is common in pedestrian bridges.

The costs shown assume a moderate level of aesthetic treatment on the structure and account for minor amounts of utility relocations typical for a project this size. Landscaping and transit infrastructure would be an additional cost and is outside the scope of this document. The cost difference between the options shown is primarily due to the area of structure that would be needed to fit the site. In addition, some options include the cost of retaining walls that would be necessary to keep the grading within the project site.

Costs reported in this section reflect the options presented in Appendix D. Due to differing site conditions at the east and west approaches, a mix of approach configurations could work for a given bridge type. Modifying approach configurations from those shown in Appendix D would result in slightly different project costs, but would be in the same general range.

Summary and Recommendations

We believe that a tunnel should not be considered at this location for reasons identified previously in this report, and that a bridge would be the most appropriate for the trail crossing. In addition, we recommend that the location of the bridge be in the vicinity of Crawford Drive.

There are numerous combinations of bridge approach types, structure types and impacts on nearby properties presented in this study. Each of these combinations are viable and provide various levels of opportunity for transit use, public gathering spaces, and connectivity to the Robert Street Corridor and other facilities. Therefore, it is difficult to recommend one concept over another. The preferred concept should be chosen based on an evaluation of community priorities.

Appendix

APPENDIX A	Site Photos Near Crawford Drive
APPENDIX B	North Urban Regional Trail (NURT) Options
APPENDIX C	Approach & Bridge/Tunnel Profile
APPENDIX D	Bridge/Tunnel Crossing At Crawford Drive Options
APPENDIX E	Structure Type Cross Sections & Examples
APPENDIX F	Pedestrian Bridge Concepts
APPENDIX G	Bridge/Tunnel Crossing Cost Estimate Matrix

Appendix A

Site Photos Near Crawford Drive



View of Northbound Robert Street Near Crawford Drive
(Looking North)



View of Southbound Robert Street Near Crawford Drive
(Looking South)

Job #7294
3/21/2011
h:\projects\7294\BRI\Plans\Feasibility Study\7294_AppA.dgn



SITE PHOTOS NEAR CRAWFORD DRIVE

ROBERT ST. IMPROVEMENTS - GRADE SEPARATED TRAIL FEASIBILITY STUDY
CITY OF WEST SAINT PAUL, MN



View of Westbound Crawford Drive



View of Eastbound Crawford Drive

Job #7294
3/21/2011
h:\projects\7294\BR\Plans\Feasibility Study\7294_AppA.dgn



SITE PHOTOS NEAR CRAWFORD DRIVE

ROBERT ST. IMPROVEMENTS - GRADE SEPARATED TRAIL FEASIBILITY STUDY
CITY OF WEST SAINT PAUL, MN



Proposed West Approach Area For Crossing At Crawford Drive
(Looking West)



Proposed West Approach Area For Crossing At Crawford Drive
(Looking West)

Job #7294
3/21/2011
h:\projects\7294\BRI\Plans\Feasibility Study\7294_AppA.dgn



SITE PHOTOS NEAR CRAWFORD DRIVE

ROBERT ST. IMPROVEMENTS - GRADE SEPARATED TRAIL FEASIBILITY STUDY
CITY OF WEST SAINT PAUL, MN

APPENDIX A
Figure 3 of 4



Proposed West Approach Area For Crossing At Crawford Drive
(Looking East)



Proposed West Approach Area For Crossing At Crawford Drive
(Looking Northeast)

Job #7294
3/21/2011
h:\projects\7294\BR\Plans\Feasibility Study\7294_AppA.dgn



SITE PHOTOS NEAR CRAWFORD DRIVE

ROBERT ST. IMPROVEMENTS - GRADE SEPARATED TRAIL FEASIBILITY STUDY
CITY OF WEST SAINT PAUL, MN

APPENDIX A
Figure 4 of 4

Appendix B

North Urban Regional Trail (NURT) Options

- LEGEND:**
- PLANNED NORTH URBAN REGIONAL TRAIL (NURT)
 - EXISTING LOCAL TRAIL / PLANNED NURT SEGMENT
 - ROBERT STREET CROSSING AT CRAWFORD DRIVE (RECOMMENDED)
 - - - ALTERNATE ROBERT STREET CROSSING (NOT RECOMMENDED)
 - - - NURT WEST CONNECTION - OPTION 1
 - - - NURT WEST CONNECTION - OPTION 2
 - - - NURT EAST CONNECTION - OPTION 1
 - - - NURT EAST CONNECTION - OPTION 2
 - = BRIDGE OR TUNNEL

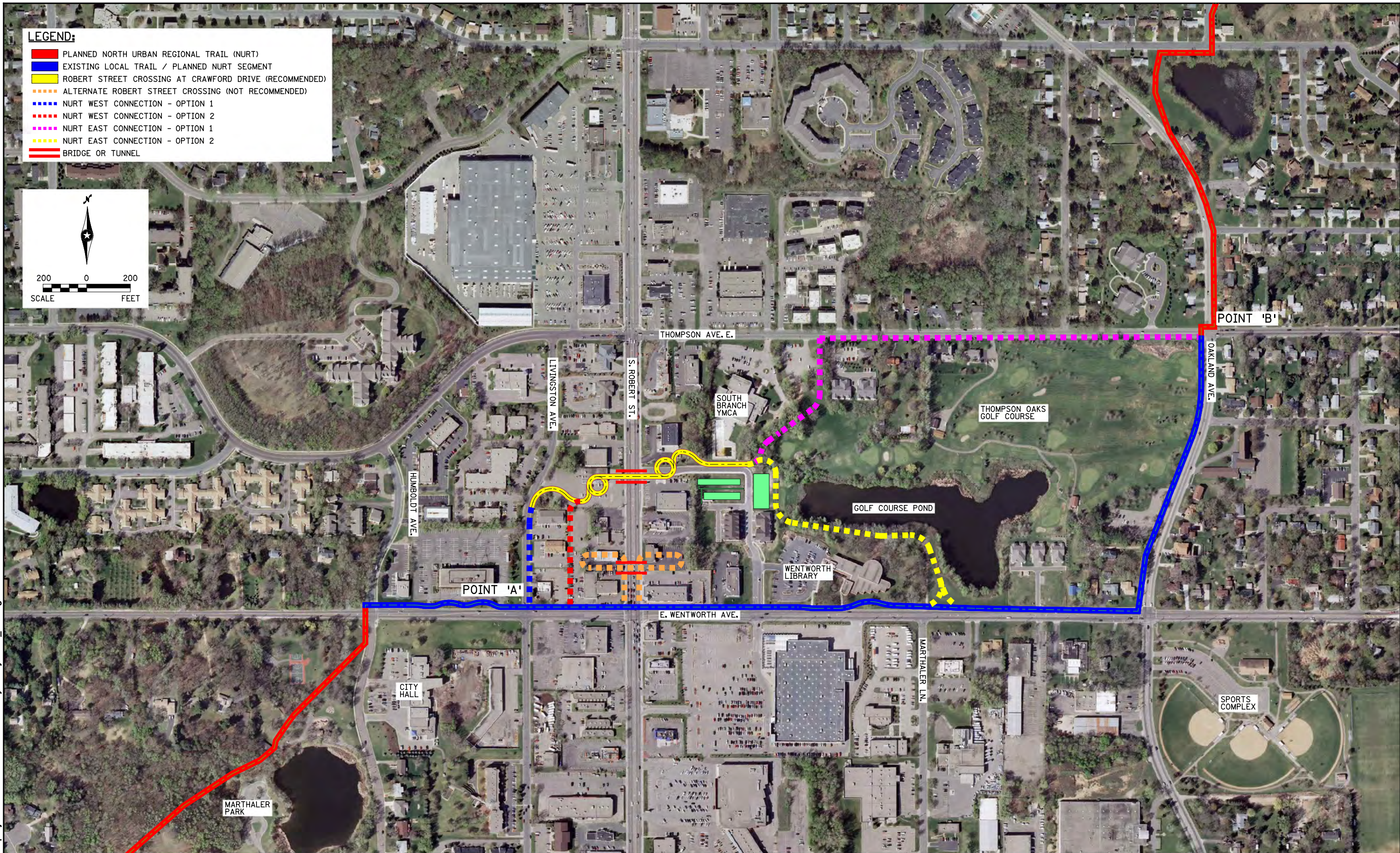
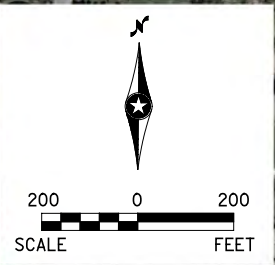

Job #7294
 4/14/2011
 h:\projects\7294\BRI\Plans\Feasibility Study\7294_trail.dgn

NORTH URBAN REGIONAL TRAIL (NURT) OPTIONS
 ROBERT STREET IMPROVEMENTS - GRADE SEPARATED TRAIL FEASIBILITY STUDY
 CITY OF WEST SAINT PAUL, MN



ROBERT STREET IMPROVEMENTS - GRADE SEPARATED TRAIL FEASIBILITY STUDY
North Urban Regional Trial (NURT) Alignment Alternatives Comparison

	LENGTH (POINT A TO B)	NUMBER OF AT-GRADE ROADWAY CROSSINGS	DISTANCE FROM WENTWORTH	MARTHALER PARK/ CITY HALL CONNECTION	LIBRARY CONNECTION	YMCA CONNECTION	SPORTS CENTER CONNECTION	NUMBER OF EXISTING BUILDINGS TO BE REMOVED
EXISTING TRAIL / PLANNED NURT SEGMENT	4350 LIN FT	6	N/A	Yes	Yes	No	Yes	0
NURT WEST CONNECTIONS & EAST CONNECTION 1	4350 LIN FT	4	630 LIN FT	Yes	No	Yes	No	1
NURT WEST CONNECTIONS & EAST CONNECTION 2	5450 LIN FT	4	630 LIN FT	Yes	Yes	Yes	Yes	1
ALTERNATE CROSSING	5650 LIN FT	5	180 LIN FT	Yes	Yes	No	Yes	2

Job #7294
3/21/2011
h:\projects\7294\BR\Plans\Feasibility Study\7294_trail_Matrix.dgn

NORTH URBAN REGIONAL TRAIL (NURT) OPTION MATRIX
ROBERT ST. IMPROVEMENTS - GRADE SEPARATED TRAIL FEASIBILITY STUDY
CITY OF WEST SAINT PAUL, MN



Appendix C

Approach & Bridge/Tunnel Profile

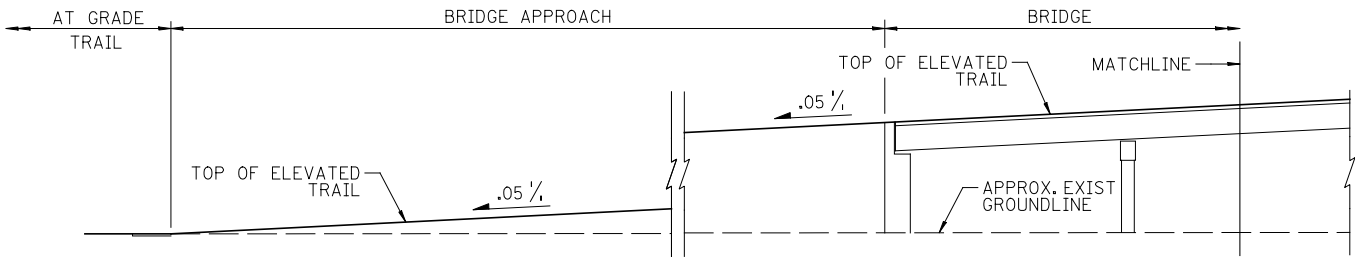

BRIDGE APPROACH
(EAST & WEST APPROACH SIMILAR)

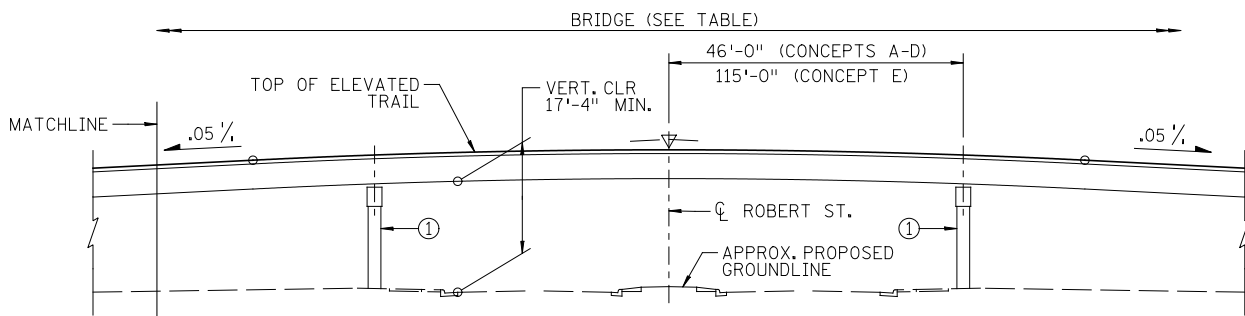

BRIDGE MAIN SPAN

NOTES

① PIERS ADJACENT TO ROADWAY TO BE SIZED TO ACCOMMODATE MnDOT PIER PROTECTION POLICY.

BRIDGE CONCEPT	APPROX. LENGTH OF BRIDGE	APPROX. LENGTH OF APPROACHES	APPROX. LENGTH OF TRAIL AT GRADE
A	555' - 0"	225' - 0"	478' - 0"
B	705' - 0"	95' - 0"	615' - 0"
C	750' - 0"	175' - 0"	785' - 0"
D	770' - 0"	146' - 0"	535' - 0"
E	675' - 0"	238' - 0"	20' - 0"



Job #7294
6/8/2011
h:\projects\7294\BR\Plans\Feasibility Study\7294_fig01.dgn

APPROACH & BRIDGE PROFILE

ROBERT ST. IMPROVEMENTS - GRADE SEPARATED TRAIL FEASIBILITY STUDY
CITY OF WEST SAINT PAUL, MN

APPENDIX C
Figure 1 of 2

Job #7294
6/8/2011
h:\projects\7294\BR\Plans\Feasibility Study\7294_fig02.dgn

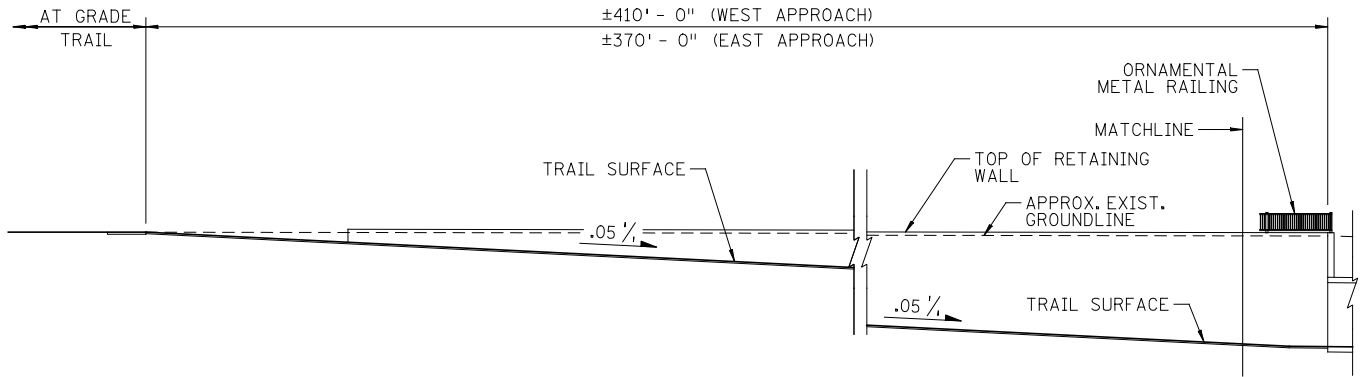

TUNNEL APPROACH
(EAST & WEST APPROACH SIMILAR)

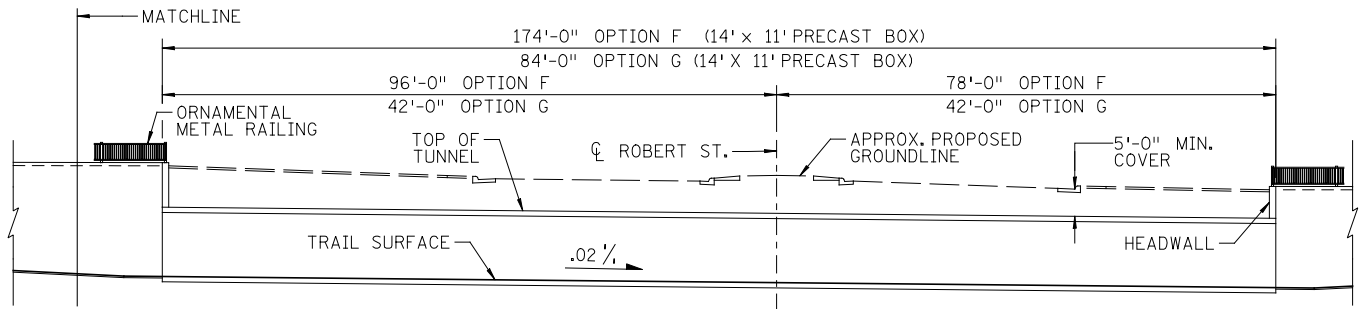

TUNNEL ELEVATION



APPROACH & TUNNEL PROFILE

ROBERT ST. IMPROVEMENTS - GRADE SEPARATED TRAIL FEASIBILITY STUDY
CITY OF WEST SAINT PAUL, MN

APPENDIX C

Figure 2 of 2

Appendix D

Bridge/Tunnel Crossing At Crawford Drive Options

- LEGEND:**
- █ EXISTING LOCAL TRAIL / PLANNED NURT SEGMENT
 - █ BRIDGE CROSSING AT CRAWFORD DRIVE
 - █ BRIDGE APPROACH
 - █ NEW PAVEMENT
 - - - NURT WEST CONNECTION - OPTION 1
 - - - NURT WEST CONNECTION - OPTION 2
 - - - NURT EAST CONNECTION - OPTION 1
 - - - NURT EAST CONNECTION - OPTION 2
 - █ POTENTIAL GREEN SPACE
 - █ POTENTIAL TRANSIT USE
 - - - EXISTING R.O.W.
 - - - ADDITIONAL R.O.W. REQUIRED

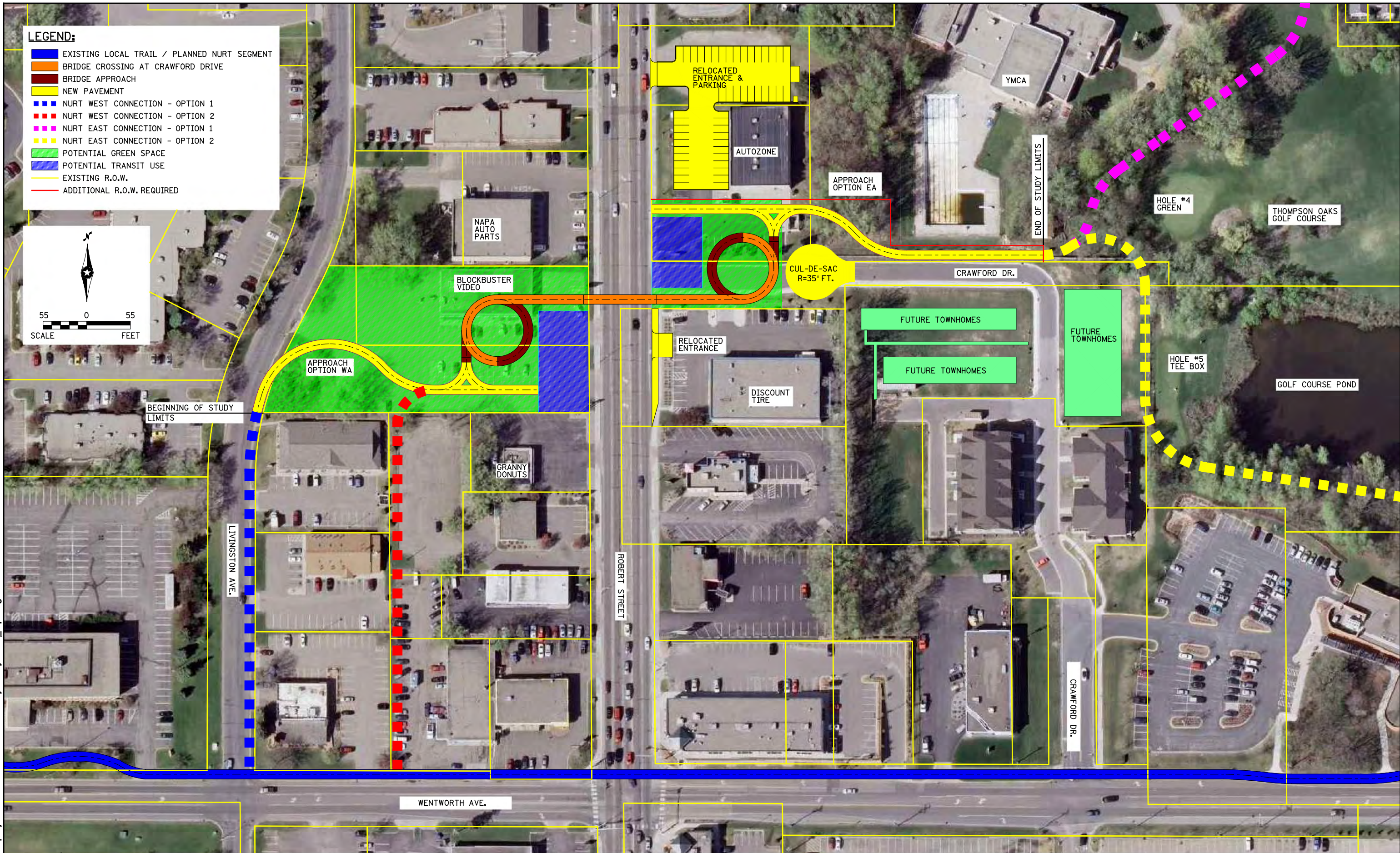
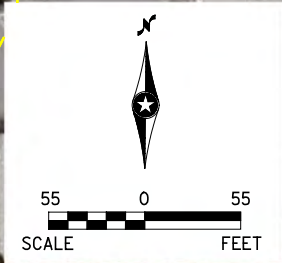

Job #7294
 6/6/2011
 h:\projects\7294\BRI\Plans\Feasibility Study\7294_OpA.dgn

BRIDGE CROSSING AT CRAWFORD DRIVE - OPTION A
 ROBERT STREET IMPROVEMENTS - GRADE SEPARATED TRAIL FEASIBILITY STUDY
 CITY OF WEST SAINT PAUL, MN



- LEGEND:**
- ▬ EXISTING LOCAL TRAIL / PLANNED NURT SEGMENT
 - ▬ BRIDGE CROSSING AT CRAWFORD DRIVE
 - ▬ BRIDGE APPROACH
 - ▬ NEW PAVEMENT
 - ▬ NURT WEST CONNECTION - OPTION 1
 - ▬ NURT WEST CONNECTION - OPTION 2
 - ▬ NURT EAST CONNECTION - OPTION 1
 - ▬ NURT EAST CONNECTION - OPTION 2
 - ▬ POTENTIAL GREEN SPACE
 - ▬ POTENTIAL TRANSIT USE
 - ▬ EXISTING R.O.W.
 - ▬ ADDITIONAL R.O.W. REQUIRED

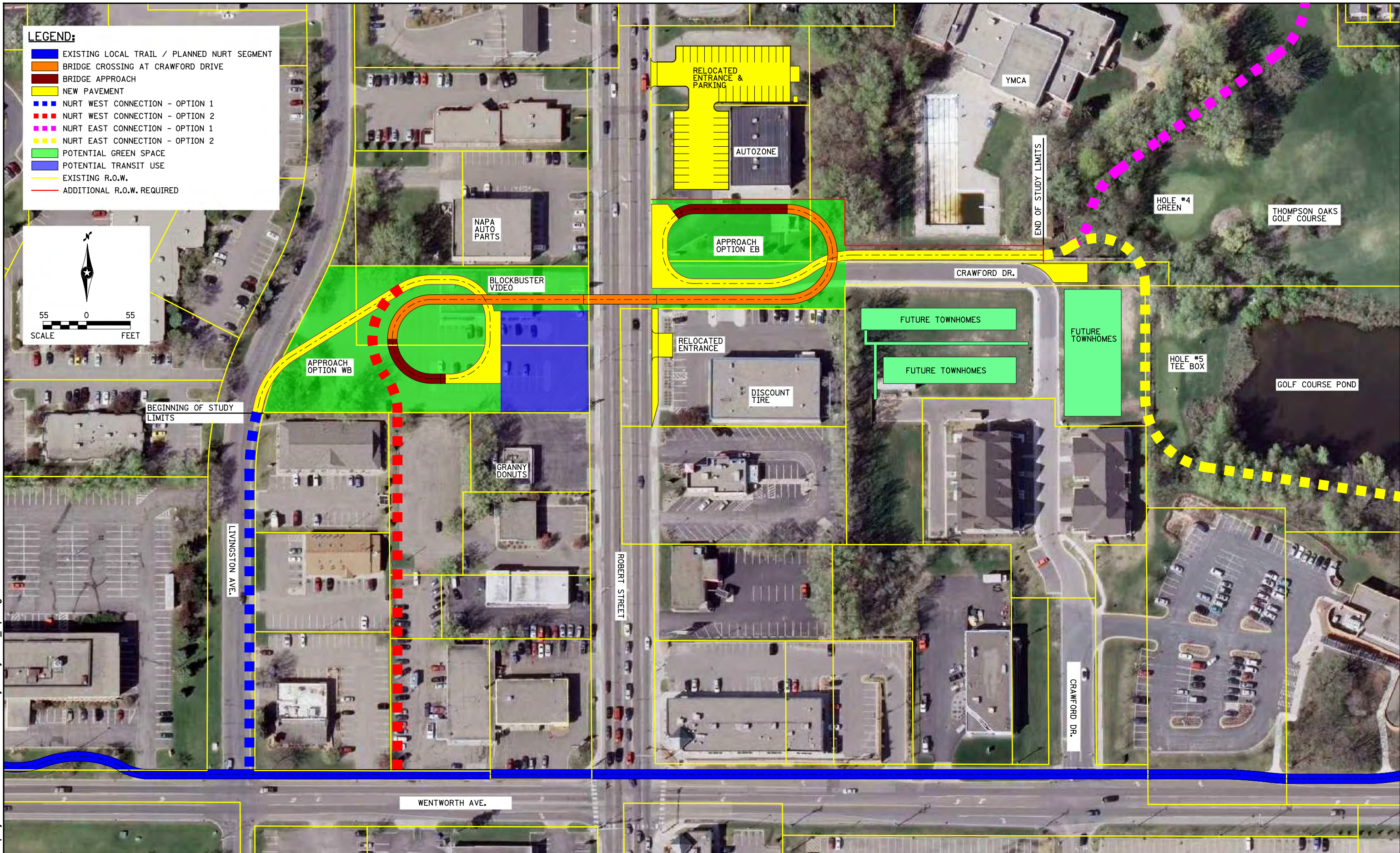
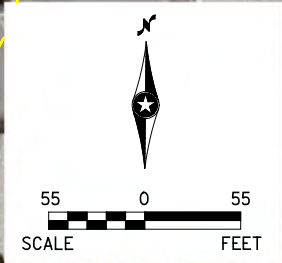

Job #7294
 6/6/2011
 h:\projects\7294\BRI\Plans\Feasibility Study\7294_OpB.dgn

BRIDGE CROSSING AT CRAWFORD DRIVE - OPTION B
 ROBERT STREET IMPROVEMENTS - GRADE SEPARATED TRAIL FEASIBILITY STUDY
 CITY OF WEST SAINT PAUL, MN



- LEGEND:**
- ▬ EXISTING LOCAL TRAIL / PLANNED NURT SEGMENT
 - ▬ BRIDGE CROSSING AT CRAWFORD DRIVE
 - ▬ BRIDGE APPROACH
 - ▬ NEW PAVEMENT
 - ▬ NURT WEST CONNECTION - OPTION 1
 - ▬ NURT WEST CONNECTION - OPTION 2
 - ▬ NURT EAST CONNECTION - OPTION 1
 - ▬ NURT EAST CONNECTION - OPTION 2
 - ▬ POTENTIAL GREEN SPACE
 - ▬ POTENTIAL TRANSIT USE
 - ▬ EXISTING R.O.W.
 - ▬ ADDITIONAL R.O.W. REQUIRED

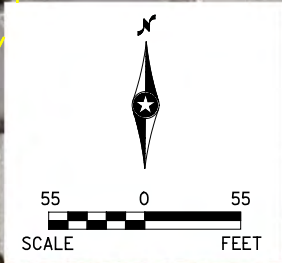

Job #7294
6/6/2011
h:\projects\7294\BRI\Plans\Feasibility Study\7294_OpC.dgn

BRIDGE CROSSING AT CRAWFORD DRIVE - OPTION C
 ROBERT STREET IMPROVEMENTS - GRADE SEPARATED TRAIL FEASIBILITY STUDY
 CITY OF WEST SAINT PAUL, MN



Job #7294
6/6/2011
h:\projects\7294\BR\Plans\Feasibility Study\7294_OpD.dgn

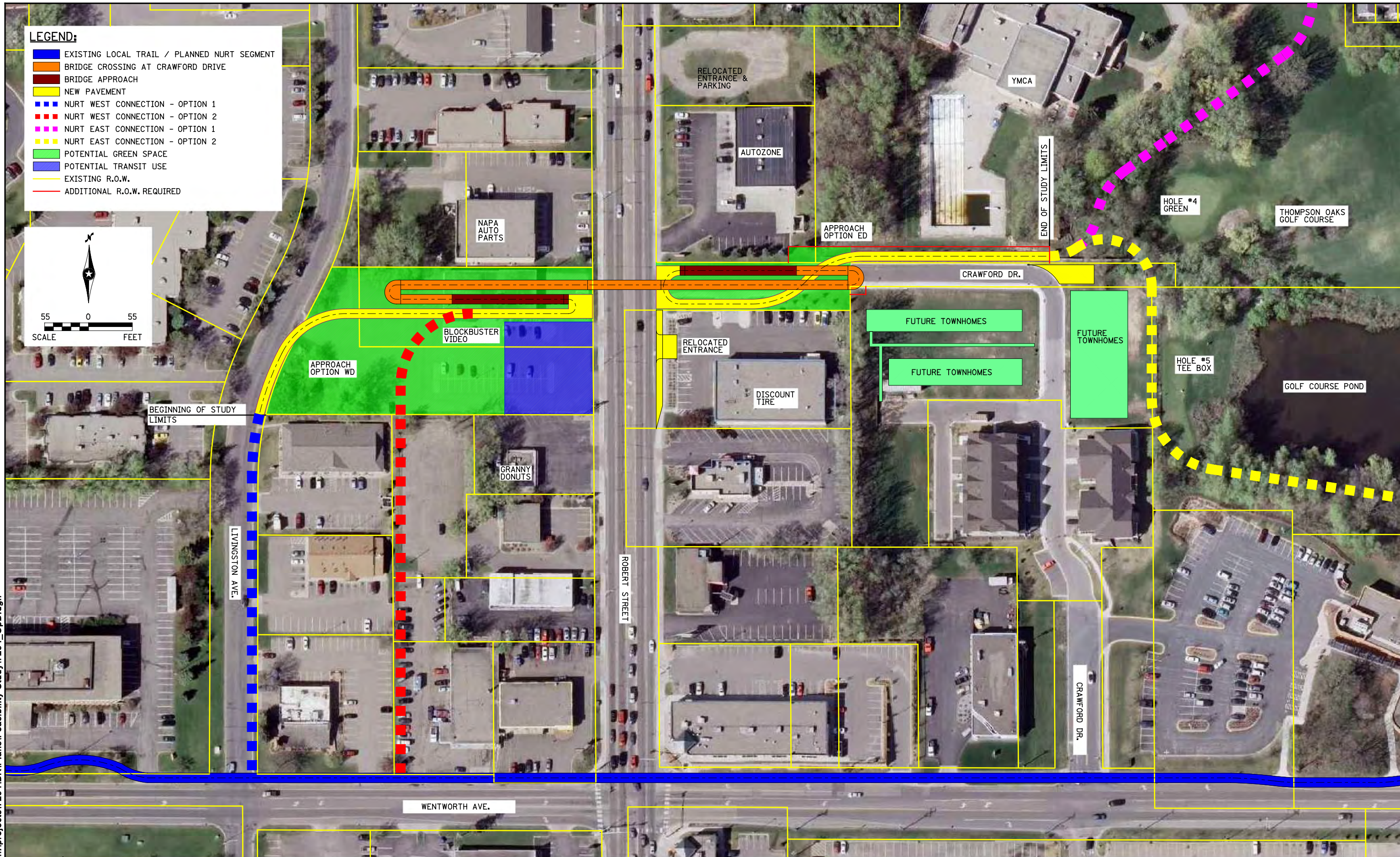

BRIDGE CROSSING AT CRAWFORD DRIVE - OPTION D
 ROBERT STREET IMPROVEMENTS - GRADE SEPARATED TRAIL FEASIBILITY STUDY
 CITY OF WEST SAINT PAUL, MN



- LEGEND:**
- █ EXISTING LOCAL TRAIL / PLANNED NURT SEGMENT
 - █ BRIDGE CROSSING AT CRAWFORD DRIVE
 - █ BRIDGE APPROACH
 - █ NEW PAVEMENT
 - █ TEMPORARY CONNECTION TO EXISTING LOCAL TRAIL
 - █ NURT WEST CONNECTION - OPTION 1
 - █ NURT WEST CONNECTION - OPTION 2
 - █ NURT EAST CONNECTION - OPTION 1
 - █ NURT EAST CONNECTION - OPTION 2
 - █ POTENTIAL GREEN SPACE
 - █ POTENTIAL TRANSIT USE
 - █ EXISTING R.O.W.
 - █ ADDITIONAL R.O.W. REQUIRED

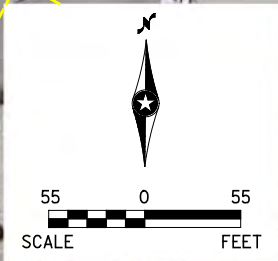

Job #7294
 6/6/2011
 h:\projects\7294\BRI\Plans\Feasibility Study\7294_OpE.dgn

BRIDGE CROSSING AT CRAWFORD DRIVE - OPTION E
 ROBERT STREET IMPROVEMENTS - GRADE SEPARATED TRAIL FEASIBILITY STUDY
 CITY OF WEST SAINT PAUL, MN



Job #7294
6/6/2011
h:\projects\7294\BR\Plans\Feasibility Study\7294_OpF.dgn

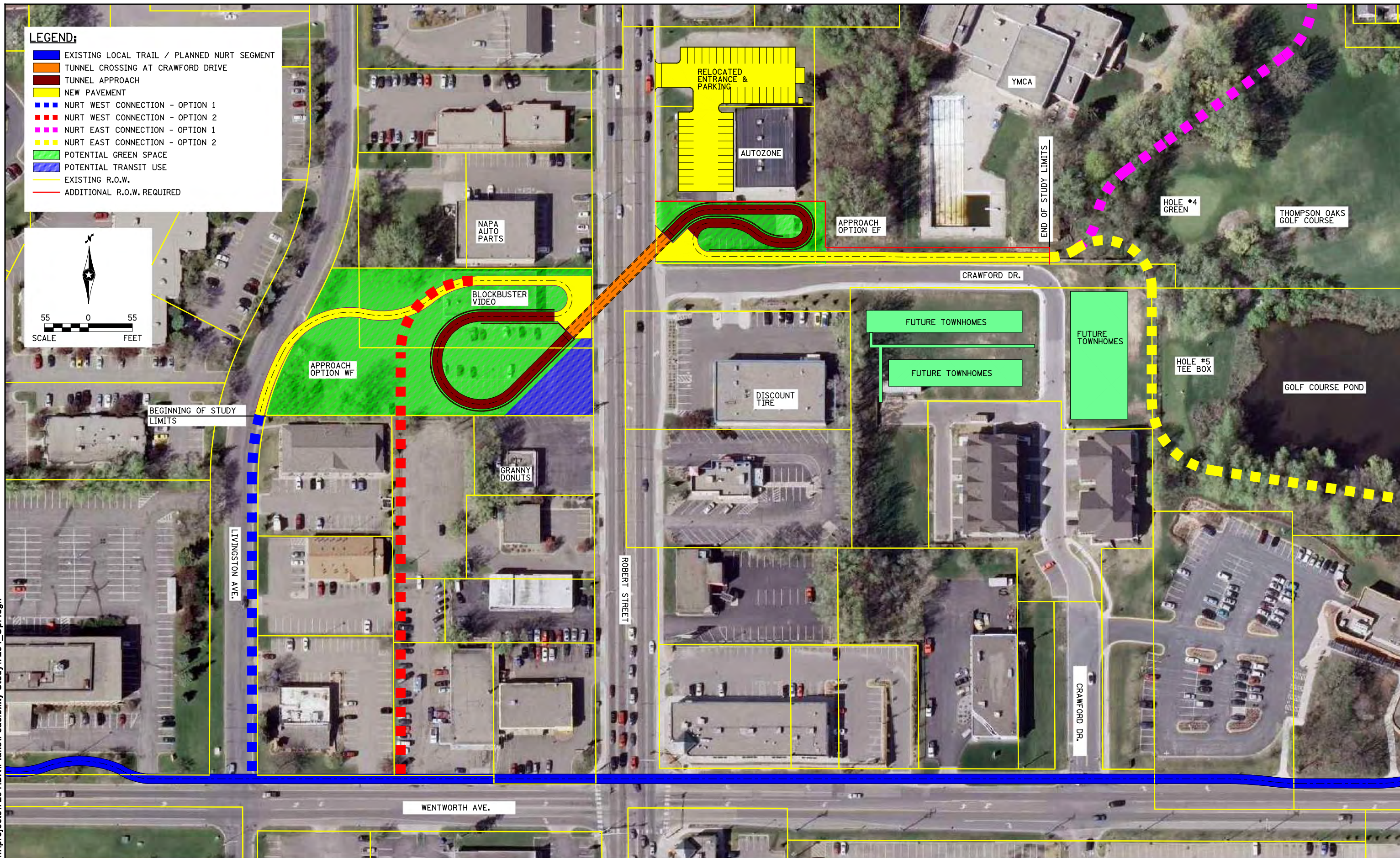

TUNNEL CROSSING AT CRAWFORD DRIVE - OPTION F
 ROBERT STREET IMPROVEMENTS - GRADE SEPARATED TRAIL FEASIBILITY STUDY
 CITY OF WEST SAINT PAUL, MN

- LEGEND:**
- █ EXISTING LOCAL TRAIL / PLANNED NURT SEGMENT
 - █ TUNNEL CROSSING AT CRAWFORD DRIVE
 - █ TUNNEL APPROACH
 - █ NEW PAVEMENT
 - - - NURT WEST CONNECTION - OPTION 1
 - - - NURT WEST CONNECTION - OPTION 2
 - - - NURT EAST CONNECTION - OPTION 1
 - - - NURT EAST CONNECTION - OPTION 2
 - █ POTENTIAL GREEN SPACE
 - █ POTENTIAL TRANSIT USE
 - - - EXISTING R.O.W.
 - - - ADDITIONAL R.O.W. REQUIRED

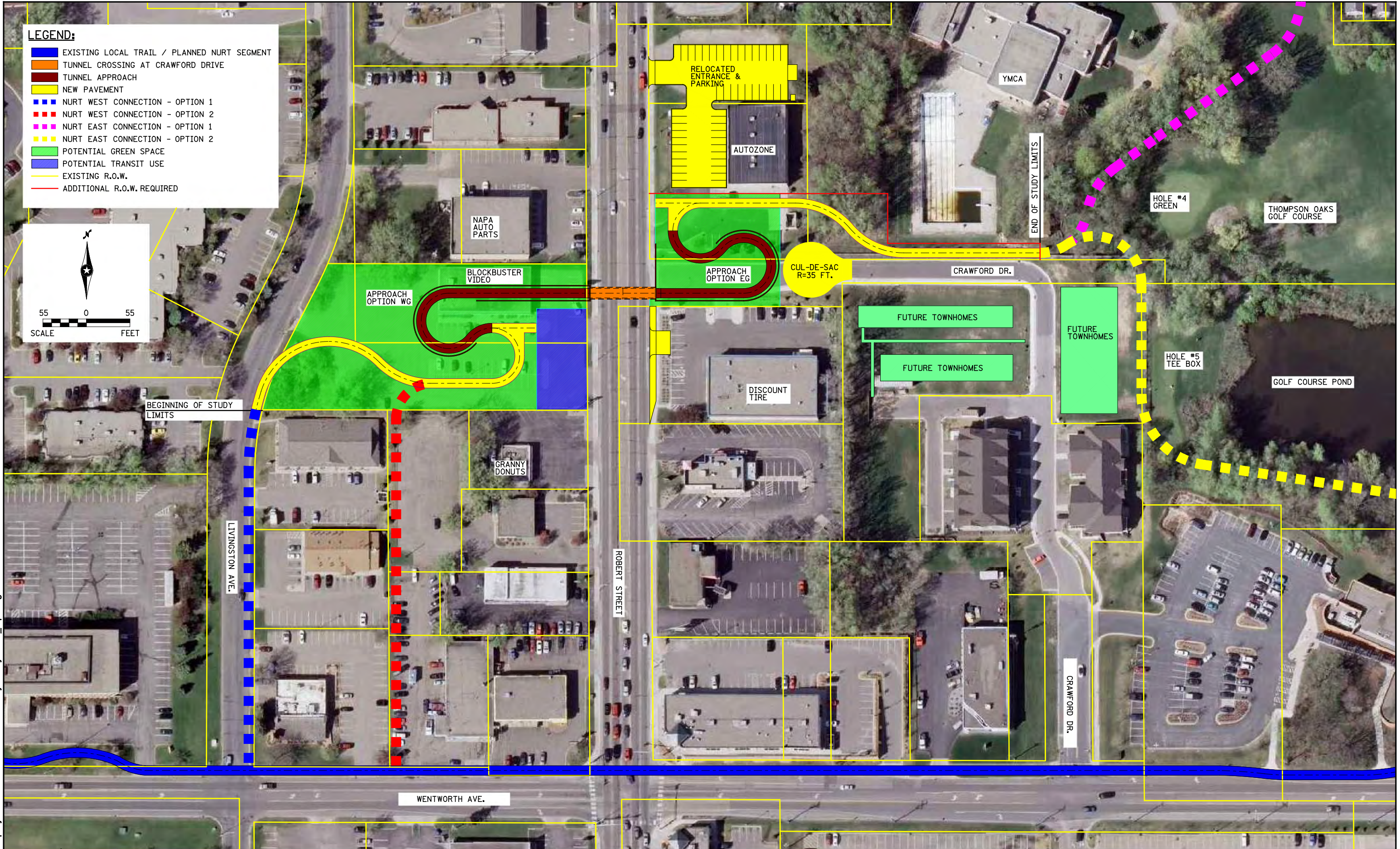
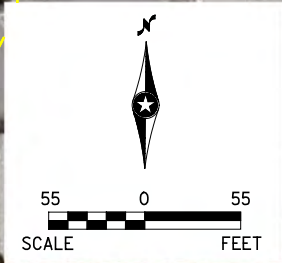

Job #7294
 6/6/2011
 h:\projects\7294\BRI\Plans\Feasibility Study\7294_OpG.dgn

TUNNEL CROSSING AT CRAWFORD DRIVE - OPTION G
 ROBERT STREET IMPROVEMENTS - GRADE SEPARATED TRAIL FEASIBILITY STUDY
 CITY OF WEST SAINT PAUL, MN



ROBERT STREET IMPROVEMENTS - GRADE SEPARATED TRAIL FEASIBILITY STUDY
Robert Street Crossing at Crawford Drive Approach Option Comparison

	APPROACH OPTION	CROSSING TYPE	MINIMUM TRAIL RADIUS (FT)	ROBERT STREET ACCESS	APPROX. AREA OF BRIDGE / TUNNEL (SQ FT)	APPROX. AREA OF APPROACH (SQ FT)	APPROX. AREA OF TRAIL AT GRADE (SQ FT)	CRAWFORD DR. OUTLET TO ROBERT ST. OPEN OR CLOSED	PARKING LOT RELOCATION	BUSINESS ENTRANCE RELOCATION	APPROX. RIGHT OF WAY TO BE ACQUIRED (ACRE)
WEST APPROACHES	WA	BRIDGE	35	Yes	7770	3150	5730	N/A	No	No	1.6
	WB	BRIDGE	50	Yes	9870	1330	7415	N/A	No	No	1.6
	WC	BRIDGE	20	Yes	10500	2450	9465	N/A	No	No	1.6
	WD	BRIDGE	9	Yes	10780	2044	6440	N/A	No	No	1.6
	WE	BRIDGE	90	No	9450	3332	205	N/A	No	No	1.6
	WF	TUNNEL	22.5	Yes	2436	5740	8395	N/A	No	No	1.6
	WG	TUNNEL	35	Yes	1176	4205	6185	N/A	No	No	1.6
EAST APPROACHES	EA	BRIDGE	35	Yes	7770	3150	6830	Closed	AutoZone	Discount Tire / AutoZone	1.1
	EB	BRIDGE	40	Yes	9870	2030	8390	Closed	AutoZone	Discount Tire / AutoZone	1.0
	EC	BRIDGE	18	Yes	10500	2870	7010	Open	AutoZone	AutoZone	1.1
	ED	BRIDGE	9	Yes	10780	2044	7030	Closed	No	Discount Tire	0.2
	EE	BRIDGE	46	No	9450	5460	4790	Closed	No	Discount Tire	0.2
	EF	TUNNEL	21	Yes	2436	5180	7130	Open	AutoZone	AutoZone	1.0
	EG	TUNNEL	35	Yes	1176	4060	6590	Closed	AutoZone	Discount Tire / AutoZone	1.1

Job #7294
6/6/2011
h:\projects\7294\BR\Plans\Feasibility Study\7294_OpMatrix.dgn

BRIDGE / TUNNEL CROSSING AT CRAWFORD DRIVE OPTION MATRIX
ROBERT ST. IMPROVEMENTS - GRADE SEPARATED TRAIL FEASIBILITY STUDY
CITY OF WEST SAINT PAUL, MN



Appendix E

Structure Type Cross Sections & Examples

Job #7294
3/21/2011
h:\projects\7294\BR\Plans\Feasibility Study\7294_fig03.dgn

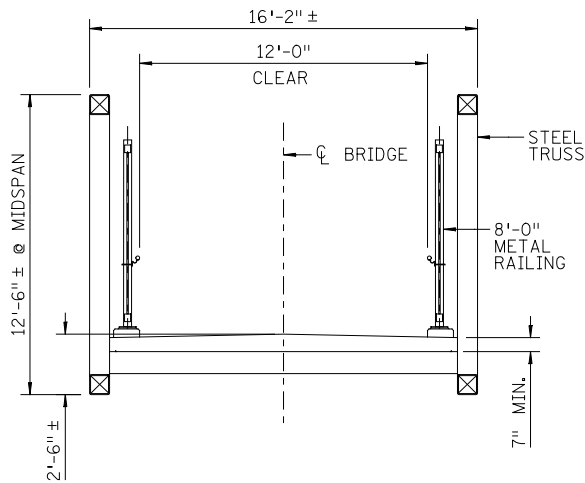

PREFABRICATED STEEL TRUSS BRIDGE

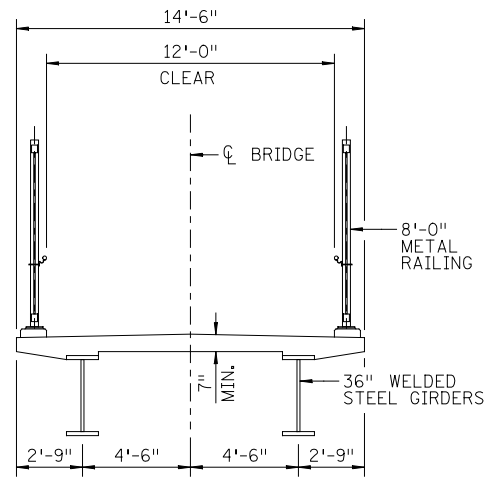

STEEL GIRDER BRIDGE

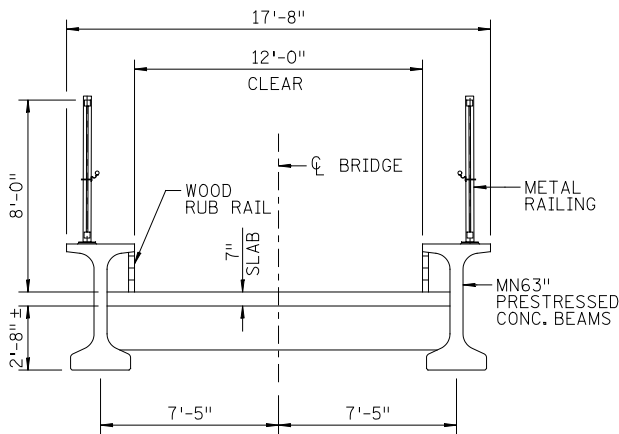

PRESTRESSED CONCRETE THROUGH GIRDER BRIDGE

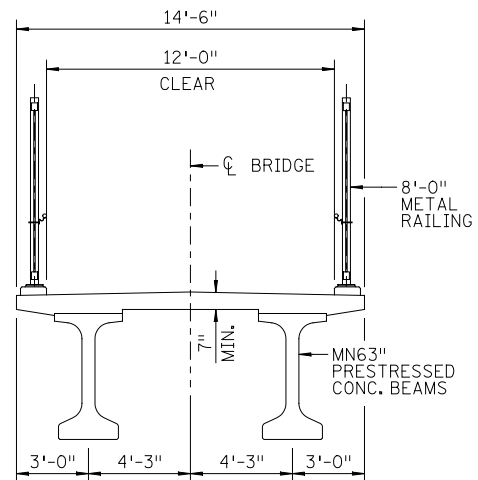

PRESTRESSED CONCRETE GIRDER BRIDGE

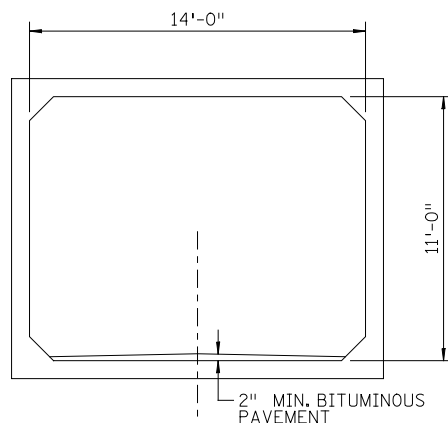

PRECAST CONCRETE BOX CULVERT TUNNEL



STRUCTURE TYPE CROSS SECTIONS

ROBERT ST. IMPROVEMENTS - GRADE SEPARATED TRAIL FEASIBILITY STUDY
CITY OF WEST SAINT PAUL, MN



STRUCTURE TYPE:

Prefabricated Steel Truss Bridge

REFERENCE PROJECT:

Pedestrian Bridge Over T.H. 65
Columbia Heights, MN

CONSTRUCTION COST:

\$2.0 Million - Constructed in 2010
\$2.3 Million - Projected Cost in 2014 Dollars

Job #7294
4/13/2011
h:\projects\7294\BR\Plans\Feasibility Study\7294_AppE.dgn



STRUCTURE TYPE EXAMPLES

ROBERT ST. IMPROVEMENTS - GRADE SEPARATED TRAIL FEASIBILITY STUDY
CITY OF WEST SAINT PAUL, MN

APPENDIX E
Figure 2 of 6



STRUCTURE TYPE:

Steel Girder Bridge

REFERENCE PROJECT:

Edinburgh Trail Bridge
Over T.H. 252
Brooklyn Park, MN

CONSTRUCTION COST:

\$1.3 Million - Constructed in 2003
\$2.1 Million - Projected Cost in 2014 Dollars



Job #7294
4/13/2011
h:\projects\7294\BR\Plans\Feasibility Study\7294_AppE.dgn

STRUCTURE TYPE EXAMPLES

ROBERT ST. IMPROVEMENTS - GRADE SEPARATED TRAIL FEASIBILITY STUDY
CITY OF WEST SAINT PAUL, MN

APPENDIX E
Figure 3 of 6



STRUCTURE TYPE:

Prestressed Concrete Through Girder Bridge

REFERENCE PROJECT:

Trail Bridge Over T.H. 7
Saint Louis Park, MN

CONSTRUCTION COST:

\$1.5 Million - Constructed in 2007
\$2.0 Million - Projected Cost in 2014 Dollars

Job #7294
4/13/2011
h:\projects\7294\BR\Plans\Feasibility Study\7294_AppE.dgn

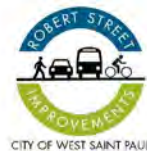

STRUCTURE TYPE EXAMPLES

ROBERT ST. IMPROVEMENTS - GRADE SEPARATED TRAIL FEASIBILITY STUDY
CITY OF WEST SAINT PAUL, MN

APPENDIX E

Figure 4 of 6



STRUCTURE TYPE:

Prestressed Concrete Girder Bridge

REFERENCE PROJECT:

Trail Bridge Over T.H. 169
Champlin, MN

CONSTRUCTION COST:

\$1.4 Million - Constructed in 2004
\$2.1 Million - Projected Cost in 2014 Dollars

Job #7294
5/4/2011
h:\projects\7294\BR\Plans\Feasibility Study\7294_AppE.dgn



STRUCTURE TYPE EXAMPLES

ROBERT ST. IMPROVEMENTS - GRADE SEPARATED TRAIL FEASIBILITY STUDY
CITY OF WEST SAINT PAUL, MN

APPENDIX E
Figure 5 of 6



STRUCTURE TYPE:

Precast Concrete Box Culvert Tunnel

REFERENCE PROJECT:

Wayzata Country Club Pedestrian Tunnel
Wayzata, MN

CONSTRUCTION COST:

\$0.4 Million - Constructed in 2004
\$0.6 Million - Projected Cost in 2014 Dollars



Job #7294
4/13/2011
h:\projects\7294\BR\Plans\Feasibility Study\7294_AppE.dgn

STRUCTURE TYPE EXAMPLES

ROBERT ST. IMPROVEMENTS - GRADE SEPARATED TRAIL FEASIBILITY STUDY
CITY OF WEST SAINT PAUL, MN

APPENDIX E

Figure 6 of 6

Appendix F

Pedestrian Bridge Concepts

Job #7294_3/21/2011
H:\Projects\7294\LA\PedBridge\7294_PedBridgeRenderings-110314-draft.incd



PEDESTRIAN BRIDGE CONCEPT A- View Looking South Along Robert Street

ROBERT STREET IMPROVEMENTS- GRADE SEPARATED TRAIL FEASIBILITY STUDY
CITY OF WEST SAINT PAUL, MN



Job #7294_3/21/2011
H:\Projects\7294\LA\PedBridge\7294_PedBridgeRenderings-110314-draft.incd



PEDESTRIAN BRIDGE CONCEPT B- View Looking South Along Robert Street

ROBERT STREET IMPROVEMENTS- GRADE SEPARATED TRAIL FEASIBILITY STUDY
CITY OF WEST SAINT PAUL, MN



Appendix G

Bridge/Tunnel Crossing Cost Estimate Matrix

ROBERT STREET IMPROVEMENTS - GRADE SEPARATED TRAIL FEASIBILITY STUDY
Robert Street Crossing at Crawford Drive Cost Estimates by Crossing Option

APPROACH OPTION	CROSSING TYPE	BRIDGE / TUNNEL AREA (SF)	ESTIMATED COST/SF	ESTIMATED STRUCTURE COST	ESTIMATED APPROACH COST	PARKING LOT RELOCATION (25 STALLS - \$4000 /STALL)	CONTINGENCY (10%)	ENG. & ADMIN. (20%)	ESTIMATED TOTAL COST (2011 DOLLARS)	
A	BRIDGE	7770	\$220	\$1,709,400	\$200,000	\$100,000	\$226,480	\$452,960	\$2,688,840	LOW EST.
			\$240	\$1,864,800	\$300,000				\$2,944,240	HIGH EST.
B	BRIDGE	9870	\$200	\$1,974,000	\$200,000	\$100,000	\$257,140	\$514,280	\$3,045,420	LOW EST.
			\$220	\$2,171,400	\$300,000				\$3,342,820	HIGH EST.
C	BRIDGE	10500	\$200	\$2,100,000	\$200,000	\$100,000	\$271,000	\$542,000	\$3,213,000	LOW EST.
			\$220	\$2,310,000	\$300,000				\$3,523,000	HIGH EST.
D	BRIDGE	10780	\$180	\$1,940,400	\$150,000	\$0	\$240,600	\$481,200	\$2,812,200	LOW EST.
			\$200	\$2,156,000	\$250,000				\$3,127,800	HIGH EST.
E	BRIDGE	9450	\$210	\$1,984,500	\$200,000	\$0	\$247,350	\$494,700	\$2,926,550	LOW EST.
			\$230	\$2,173,500	\$300,000				\$3,215,550	HIGH EST.
F	TUNNEL	2436	\$410	\$998,760	\$700,000	\$100,000	\$230,326	\$460,652	\$2,489,738	LOW EST.
			\$535	\$1,303,260	\$900,000				\$2,994,238	HIGH EST.
G	TUNNEL	1176	\$635	\$746,760	\$700,000	\$100,000	\$199,960	\$399,920	\$2,146,640	LOW EST.
			\$850	\$999,600	\$900,000				\$2,599,480	HIGH EST.

Job #7294
6/8/2011
h:\projects\7294\BR\Plans\Feasibility Study\7294_EstMatrix.dgn

BRIDGE/TUNNEL CROSSING COST ESTIMATE MATRIX

ROBERT ST. IMPROVEMENTS - GRADE SEPARATED TRAIL FEASIBILITY STUDY
 CITY OF WEST SAINT PAUL, MN



APPENDIX G
Figure 1 of 1